

# General Safety Regulations

## GSRs

Each car, regardless of class or category, must complete and satisfactorily pass inspection of a qualified Tech Scrutineer before being allowed to make a trial run or participate in any event.

Throughout this Appendix, a number of references are made for particular products to meet certain specifications (i.e.: FIA, SFI, SNELL, DOT, etc.). It is important to realise that these products are manufactured to meet certain specifications, and upon completion, The manufacturer labels his product as meeting that spec. Therefore, except as outlined under SFI or FIA requirements, any change to the product voids that certification; under no circumstances may any certified product be modified, altered or in any way vary from the as-manufactured condition; such a practice is in violation of the FIA, SFI, SNELL, DOT, etc., program and in so doing voids such certification.

### GSR 0:1 EXPIRATION PERIODS SFI SPECIFICATIONS, QUICK-GUIDE

SFI Spec	Description	7.50 & Quicker, or Comp Classes prefix A or B	All Other Classes Included in this Rulebook
1.1	Replacement Flywheels and Clutch Assemblies	2 Years	4 Years
1.2	Multiple Disc Clutch Assemblies	2 Years	4 Years
1.3	Nitro-Methane Drag Race Multiple Disc Clutch Assemblies	1 Year	1 Year
1.4	Alcohol Drag Race Multiple Disc Clutch Assemblies	1 Year	1 Year
1.5	Multiple Disc Clutch Assemblies for Supercharged, Nitrous Oxide-injected, and Turbocharged Vehicles	1 Year	1 Year
2.1A	Rear Engine Dragster Roll Cage - 5.99 Seconds & Quicker (Alcohol or Methanol)	FIA Only	FIA Only
2.2C	Front Engine Dragster Roll Cage - 5.99 Seconds & Quicker	FIA Only	FIA Only
2.3N	Rear Engine Dragster Chassis Structure (Top Fuel) - 6.29 Seconds & Quicker (Top Fuel)	FIA Only	FIA Only
2.4C	Front Engine Dragster Roll Cage - 6.00 to 7.49 Seconds	3 Year	3 Year
2.5C	Rear Engine Dragster Roll Cage - 6.00 to 7.49 Seconds	3 Year	3 Year
2.6A	Front Engine Dragster Roll Cage - 7.50 Seconds & Slower	N/A	3 Year
2.7C	Rear Engine Dragster Roll Cage - 7.50 Seconds & Slower	N/A	3 Year
3.2A	Driver Suits (3.2A/1, 3.2A/3, 3.2A/5)	N/A	N/A
3.2A	Driver Suits (3.2A/15, 3.2A/20)	5 Years	5 Years
3.3	Driver Accessories:	N/A	N/A
	Arm Restraints (3.3)		
	Shoes (3.3/5)		
	Drag Boots (3.3/15, 3.3/20)		
	Gloves (3.3/5, 3.3/15, 3.3/20)		
	Helmet Skirts (3.3/5)		
	Hoods/Balaclavas (3.3)		
	Neck Collar (3.3)		
4.1	Automatic Transmission Shields (Rigid Type)	5 Years	5 Years
4.1	Automatic Transmission Shields (Flexible-Blanket Type)	2 Years	2 Years

6.1	Containment Bellhousing for SFI 1.1 & 1.2 two disc maximum Clutch Assemblies or SFI 1.1 & 1.2 three disc (8-inch diameter maximum) Clutch Assemblies used only on naturally aspirated vehicles	5 Years	5 Years
6.1W	Passenger Car Replacement Containment Bellhousing with Adjustable Clutch Window for SFI 1.1 & 1.2 Single Disc Clutch or Two Disc (8-inch dia. Maximum) Clutch Assemblies Used Only on Naturally Aspirated Vehicles	2 Years	2 Years
6.2	Containment Bellhousing for SFI 1.3 & 1.4 Clutch Assemblies	2 Years	2 Years
6.3	Containment Bellhousing for SFI 1.2 greater than two disc Clutch Assemblies used on naturally aspirated vehicles or SFI 1.1 & 1.2 Clutch Assemblies used on supercharged/nitrous injected vehicles	2 Years	2 Years
7.1	Lower Engine Containment Device	1 Year	1 Year
7.2	Sportsman Lower Engine Containment Device	N/A	5 Years
9.1	Sport Compact Bellhousing Blanket	5 Years	5 Years
10.1E	Funny Car Roll Cage (Alcohol, Advanced ET, etc.)	See Class Rules	See Class Rules
10.2	Altered Car Roll Cage, 6.00 to 7.49 Seconds E.T.	3 Year	3 Year
10.3	Altered Car Roll Cage, 7.50 Seconds and Slower E.T.	3 Year	3 Year
10.4	Side Steer Roadster Roll Cage, 7.50 Seconds and Slower E.T.	3 Year	3 Year
10.5	Fuel Funny Car Chassis	FIA Only	FIA Only
14.1	Supercharger Restraint Devices	2 Years	2 Years
14.2	Alcohol Supercharger Restraint Devices	2 Years	2 Years
14.21	Screw-Type Supercharger Restraint Devices	2 Years	2 Years
14.3	Nitro-Methane Fuel Supercharger Restraint Devices	2 Years	2 Years
14.4	Containment Valve Covers/Valve Cover Shields	FIA Only	FIA Only
15.1	Drag Race Drive Wheels	N/A	N/A
15.2	Drag Race Front Wheels	N/A	N/A
15.3	High Horsepower Drag Race Drive Wheels	2 Years	2 Years
15.4	Top Fuel and Funny Car Drag Race Drive Beadlock Wheels	1 Year	1 Year
16.1	Driver Restraint Assemblies	2 Years	2 Years
17.1	On Board Fire Suppression Systems	2 Years (6 Year Max Service Life)	2 Years (6 Year Max Service Life)
18.1	Crankshaft Hub Harmonic Dampers	N/A	N/A
24.1	Youth Helmets	N/A	N/A
25.1E	Full Bodied Car Tube Chassis Roll Cage - 7.49 Seconds ET and Quicker; 2,800 Lbs. Maximum	3 Years	3 Years
25.2	Full Bodied Car Tube Chassis Roll Cage - 7.49 Seconds and Quicker; 3,200 Lbs. Maximum	3 Years	3 Years

25.3	Full Bodied Car with Aftermarket Body Shell and Tube Frame, OEM Body Shell and OEM Frame with OEM or Modified Floorpan and Firewall, or Uni-Body with OEM or Modified Floorpan and Firewall Roll Cage - 6.50 to 7.49 Seconds ET; 3,600 Lbs. Maximum	3 Years	3 Years
25.4	Full Bodied Car Tube Chassis Roll Cage - 7.50 to 8.49 Seconds ET; 3,600 Lbs. Maximum	3 Years	3 Years
25.5	Full Bodied Car Stock or Modified/OEM Floorpan and Firewall with OEM Frame or Uni-Body Construction - 7.50 to 8.49 Seconds ET; 3,600 Lbs. Maximum	3 Years	3 Years
27.1	Window Nets	2 Years	N/A
28.1	Fuel Cells	N/A	N/A
29.1	Automatic Transmission Flexplates	3 Years	3 Years
29.2	High Horsepower Automatic Transmission Flexplates	3 Years	3 Years
29.3	Automatic Transmission Flexplates for Diesel Applications	3 Years	3 Years
30.1	Automatic Transmission Flexplate Shields	5 Years	5 Years
31.1	Flame Resistant Motorsports Helmets	N/A	N/A
34.1	Screw-Type Superchargers	3 Years	3 Years
38.1	Head and Neck Restraint Systems	N/A	N/A
40.1	Abrasion Resistant Driver/Rider Suits	N/A	N/A
42.1	Steering Wheel Quick Disconnect/Release	N/A	N/A
43.1	Drive Shafts	N/A	N/A
45.1	Roll Cage Padding	N/A	N/A
46.1	Nitro-Methane Fuel Motorcycle Engine Restraint Device	2 Years	2 Years
49.1	Top Fuel Rear Wing Assemblies	N/A	N/A
54.1	Non-Flamable Thermal Barrier Fire Extinguishing Coatings	Annual Recoating	

Class rules and General Safety Rules have always priority over this quick-guide.

## **ENGINE: GSR 1**

### **GSR 1:1 COOLING SYSTEM.**

All cooling systems/radiators must be installed in the stock location for body style used.

### **GSR 1:2 ENGINE.**

Classes limited to automotive engines only unless otherwise stated under Class Requirements. No allowance for overbore; any part of a cubic centimetre (cubic inch) is rounded off to the next highest inch (i.e.: 301.2 = 302). If engine size is changed during a race, competitor must report to scrutineer before a run is attempted. Crankshaft centrelines must not exceed 610 mm (24-inch) from ground in any class. Engine must be mounted to frame by a minimum of two 10 mm (3/8-inch) diameter grade 5 (or Class 8.8) bolts.

Valve train must incorporate conventional automotive coil spring design; use of pneumatic-type valve trains is prohibited in all classes.

All classes, with the exception of ET cars slower than 10.99-seconds (\*6.99), the use of a cast iron harmonic balancer is prohibited; units meeting SFI Spec 18.1 or steel billet harmonic balancer made in one piece mandatory. All cars with pressed-on front harmonic balancers must have such installed to prevent accidental loss (i.e.: drilled and bolted).

### **GSR 1.2.1 ROTARY ENGINE.**

For classification of engine size of rotary engines, the actual engine size is multiplied by 2.2

### **GSR 1:3 EXHAUST.**

All cars must be equipped with exhaust collectors, installed to direct exhaust out of car body to rear of car, away from driver and fuel tank. If mufflers are used, they must be securely attached to exhaust system and car body or frame. Flexible tubing or flex pipe prohibited in all categories.

### **GSR 1:4 FLASH SHIELDS.**

Carburettor inlet must not be openly exposed. In place of hood, carburetors must be equipped with a flash shield or velocity stacks which cover the top, back and sides, preventing fuel from being siphoned into the airstream or blown into driver's face.

Additionally, any car that is driven, not towed, through the pits, with open stack(s) not protected by hood or scoop, must have screening installed on open stack(s) to prevent items from entering stack.

## **GSR 1:5 FUEL SYSTEMS**

### **Location**

All fuel tanks, lines, pumps, valves etc., must be outside of the driver's compartment and within the confines of the frame and/or steel body. Fuel tanks located in front of grille must be protected against collision damage by the frame or by a protection-bar with minimum dimension 32 x3 mm steel or (1 ¼ x 0,065 inch) chrome moly tubing. (i.e.: steel nerf bars, frame rail extensions, etc.). Cool cans in full-bodied cars, must be mounted a minimum of 152 mm (6-inches) forward of firewall. Fuel blocks must be located at least 152 mm (6-inches) forward of the flywheel/bellhousing area.

#### **Tanks**

All tanks must be mounted inside the body-line and isolated from driver compartment by a firewall completely sealed to prevent any fuel from entering the driver's compartment. When permitted by class regulations, fuel tanks located outside body and/or frame must be enclosed in a steel tube frame constructed of minimum 1 1/4-inch ( 32 mm) O.D. x 0.065-inch ( 1.65 mm) chrome moly or 0.118-inch (3.0 mm) mild steel tubing. All fuel tanks must have a pressure cap and be vented outside of body. A positive-locking screw-on fuel tank cap is mandatory on all open-bodied cars. Insulated fuel tanks prohibited. When used, fuel cells must have a metal box protecting the part of the cell which is outside of body lines or trunk floor excluding hose connection area in rear. **See PIC. 6**

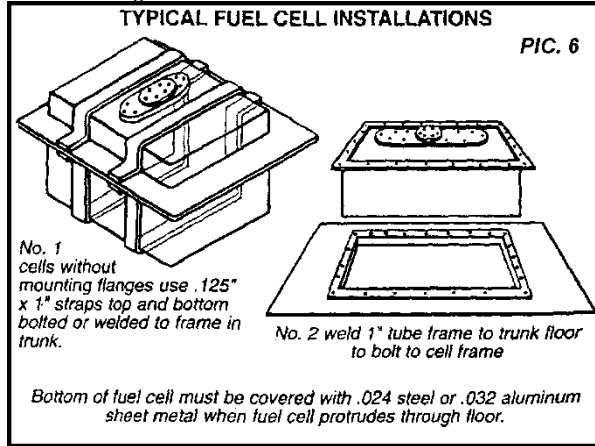

#### **Lines**

All non-OEM fuel lines (including gauge and/or data recorder lines) must be metallic, steel-braided or FIA accepted "woven pushlock". A maximum of 305 mm (12-inches)(front to rear) of non-metallic or non-steel braided is permitted for connection purposes only; individual injector nozzle lines are excluded. Fuel lines (except steel braided lines) in flywheel/bellhousing area must be enclosed in a 406 mm (16-inch) length of steel tubing, 3.2 mm (1/8-inch) minimum wall thickness, securely mounted as a protection against fuel line rupture. FIA accepted woven pushlock fuel line: Aeroquip FC300, FC332 and Aeroquip Star Lite 200. Contact FIA for updates. Fuel lines must not be routed in the driveshaft tunnel.

#### **Pumps/valves**

Cars with non-OEM type mechanical fuel pumps must have a quick-action fuel shut off valve within easy reach of driver and located in main fuel line between the fuel tank and the carburettor and/or injectors. Fuel recirculation systems not part of normal fuel/pump system prohibited.

#### **Fuel/air**

Any method of artificially cooling or heating fuel prohibited (i.e.: cool cans, ice, freon, wet rags, etc.), except as noted in Class Requirements.

#### **GSR 1:5.1 INTERCOOLER.**

Addition of fuel to intake air before intercooler prohibited.

#### **GSR 1:6 GASOLINE/ PETROL.**

Gasoline/ Petrol is defined for purposes of this Appendix as a mixture of hydrocarbons only. Non-hydrocarbons which do not increase the specific energy of the gasoline/ petrol are allowed to the extent that they do not exceed 0.15% by volume and are blended in the gasoline by the refiner or fuel manufacturer.

Gasoline/ petrol is a good electrical insulator, or dielectric, and its relative effectiveness as an insulator is represented by its Dielectric Constant. The average D.C. for the hydrocarbons which comprise gasoline/ petrol is 2.025. This is defined as a reading of "0" with the FIA/ MSA Fuel Check meter.

#### **GSR 1:7 LIQUID OVERFLOW.**

All cars in competition with any type of water overflow capable of spilling water must have a catch-can to accumulate the excess liquids and not leak onto the track. Minimum catch-can capacity: 0,5 litre (1 pint) Catch-can must be securely fastened; i.e. bolted, clamped..

#### **GSR 1:9 NITROUS OXIDE.**

Nitrous oxide allowed . See specific Class Requirements & Specifications. The use of any agents other than nitrous oxide as part of, or mixed with, this pressurised fuel system is strictly prohibited. All bottles must be securely mounted, and only gas cylinders certified for use at the working pressure of the system as a fuel reservoir (also applicable to any vehicle with a pressurised gas system) permitted. All receiving cylinders should have rupture disc or safety valve to prevent over pressurisation. The bottle to solenoid supply pipe should be of steel or high quality steel braided teflon hose e.g. Aeroquip and securely fastened every 6" (15.24 cm) with non-combustible clips and fasteners. All fittings must be of a screwed sealing type. All systems must include a device which prevents the system being activated before the throttle is operated. A 'Warning Light' clearly labelled N2O must be wired into the solenoid circuit so that it is illuminated when the N2O system is armed. Nitrous oxide bottle(s) located in driver compartment must be equipped with a relief valve and vented outside of compartment. System must be commercially available and installed per manufacturers recommendations. Bottle may not be mounted in engine compartment.

**Advisory check:** Generally check for leaks whilst the cylinder is turned on to verify gas tight connections. The shut off solenoid must be checked (with the gas cylinder turned on) by fully opening the throttle momentarily to determine whether N2O is being discharged (all nitrous lines must be disconnected and discharged into the open air, and all fuel solenoids must be electrically unplugged). The throttle must then be released to about half throttle and held in that position. This should release the solenoid, which is activated by the throttle switch and cut off the flow of gas. Further checks should be made to ensure that any slight hiss of escaping gas can be detected. All vehicles using a bottle of nitrous oxide must bear a mark in accordance with **(illustration PIC. 2)**

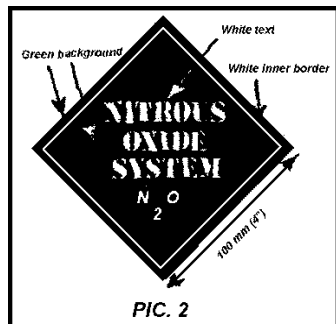

The mark will be clearly visible and will be located in a place which is not likely to be damaged in the event of an accident and which is near to the competition number. Venting and refilling of N2O bottles should be undertaken with extreme caution. External heating of bottle(s) by electric blanket for the purpose permitted.

#### **GSR 1:10 OIL SYSTEM.**

Accu-sump, dry-sump tanks, oil filters, oil supply lines, etc., prohibited in driver compartment and outside of frame and/or steel body/fenders. Oil pressure gauge and line permitted in driver compartment. Metal or steel braided line mandatory, maximum 5 mm (3/16-inch) inside diameter.

#### **GSR 1:11 PROPYLENE OXIDE.**

The use of propylene oxide is prohibited in all categories.

#### **GSR 1:12 SUPERCHARGER.**

##### **ROOTS-TYPE:**

Maximum size permitted 14-71; 19-inch (483 mm) maximum rotor case length; 11 1/4-inch (286 mm) maximum case width; 1/4-inch (6.35 mm) minimum case thickness; 1/4-inch (6.35 mm) minimum front plate thickness; .300-inch (7.6 mm) minimum rear plate thickness. Maximum rotor cavity diameter is 5.840 inches (148.34 mm). Rotor helix angle may not exceed that of a standard 71-series GM-type rotor 4 degrees per inch (1.5748°/cm). Maximum overdrive may not exceed 70 percent. Aluminium studs (supercharger to manifold) mandatory. **See GSR 1.13** and Class Requirements for manifold burst panel and restraint specifications.

##### **ROOTS-TYPE HIGH HELIX:**

Must adhere to same maximum case dimensions and maximum rotor cavity diameter as standard Roots. Rotor helix angle may not exceed 6.5-degrees per inch (2.559°/cm), and 123.5 degrees total over 19-inch (483 mm) maximum rotor length. Use of High-Helix supercharger is restricted to TMD and TMFC only, prohibited in all other classes. Maximum overdrive may not exceed 70 percent. Aluminium studs (supercharger to manifold) mandatory. **See GSR 1.13** Class requirements for manifold burst panel and restraint specifications.

##### **ALL SUPERCHARGERS**

Variable multi-speed supercharger devices prohibited regardless of supercharger type. A belt guard or other protection device is required when fuel and/or oil lines pass supercharger drive belt area.

#### **GSR 1:13 SUPERCHARGER RESTRAINT DEVICE.**

Supercharger restraint system meeting SFI Specs mandatory per class requirements, ET cars running 7.49 seconds or quicker Roots-type require an SFI 14.2 restraint. Restraint system must be updated at year intervals as per spreadsheet under GSR: 0:1 from date of manufacture. See also Class Requirements.

#### **GSR 1:14 THROTTLE.**

Regardless of class, each car must have a foot throttle incorporating a positive-acting return spring attached directly to the carburettor/injector throttle arm. A positive stop or override prevention must be used to keep linkage from passing over centre, sticking in an open position. In addition to return springs, some means of manually returning the throttle to a closed position by use of the foot must be installed on all altered linkage systems except hydraulically or cable-operated systems. Per Class Requirements - Throttle control must be manually operated by driver's foot, electronics, pneumatics, hydraulics or any other device may in no way affect the throttle operation. FIA or MSA accepted hand controls for the physically challenged permitted. Commercially available cable throttle systems are allowed. Choke cables and brazed or welded fittings on steel cable are prohibited. No part of throttle linkage may extend below frame rails.

#### **GSR 1:15 VENT TUBES, BREATHERS.**

Mandatory as outlined in Class Requirements, permitted on all cars. Where used, the tubes must terminate into an acceptable, permanently attached catch-tank with a minimum capacity of 3.8 litre per engine. The catch-tank must be baffled to keep overflow off track. A sight glass or tube is recommended to verify that tank is empty prior to run. Breather/vent tubes must be mechanically secured (tie-wraps prohibited) to the fittings and fittings locked at both ends.

## **DRIVE TRAIN: GSR 2**

#### **GSR 2:1 ANTI-BLOWBACK DEVICE.**

If mandated by Class Requirements a brace or device must be installed that will prevent the bellhousing or adapter shield from being blown rearward in the event of flywheel and/or clutch explosion. Material required is 4130 chrome moly (or Reynolds 531), minimum size is 22.2 mm(0.875-inch) O.D. x 2,1 mm (0.083-inch) wall tubing with 10 mm (3/8-inch) fasteners. Ball-lock pins prohibited. **See illustration PIC. 7.**

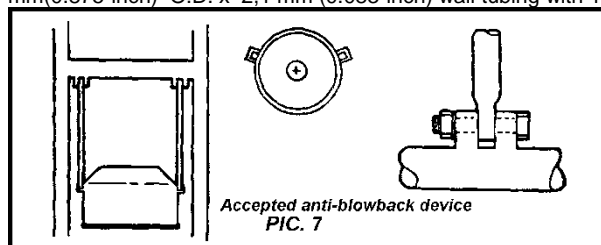

## GSR 2:2 AXLE-RETENTION DEVICES.

All cars, must be equipped with a satisfactory means of rear-axle retention.

## GSR 2:3 CLUTCH.

Each car in competition, except those with automatic transmissions, must be equipped with a foot-operated clutch incorporating a positive stop to prevent clutch from going over centre or past neutral as in the case of centrifugal units. All pedals must be covered with non-skid material. FIA accepted hand controls for physically challenged permitted. All slider clutches must meet SFI Spec 1.2, 1.3 or 1.4 as outlined under Class Requirements.

## GSR 2:4 DRIVELINE.

In place of a crossmember, in the vicinity of the front universal joint, all cars in competition using open driveshafts, must have a retainer loop 360-degrees of enclosure, 6 mm (1/4-inch) minimum thickness and 51 mm (2-inches) wide, or 22 mm (7/8-inch) x 1,65 mm (0.065-inch) welded steel tubing, securely mounted and located within 152 mm (6-inches) of the front universal joint for support of the driveshaft in event of U-joint failure. Recommended the loop be round rather than oblong to minimise loading on loop. Open drivelines passing any part of the driver's body must be completely enclosed in 3 mm (1/8-inch) minimum thickness steel plate, securely mounted to the frame or frame structure. **See PIC. 8.**

**Except vehicles running slower than 10.00secs and being manufactured in or after 2010 with only modifications outlined in GSR 14:10.1**

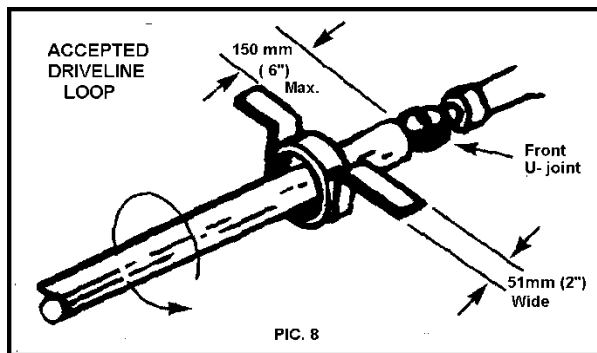

## GSR 2:5 FLYWHEEL.

The use of stock-type cast iron flywheels and/or pressure plates prohibited. Units meeting SFI Spec 1.1, 1.2, 1.3 or 1.4 are mandatory except as noted in the Class Requirements.

## GSR 2:6 FLYWHEEL SHIELD & MOTOR PLATE.

### General

The use of an aluminium bellhousing is permitted in all classes, so long as it meets applicable SFI Specifications.

Absolutely no modifications to as-manufactured design are permitted on SFI Spec 6.1, 6.2 and 6.3 or 9.1 flywheel shields and/or liners. Titanium and Aluminium SFI 6.1, and Steel SFI 6.2 and 6.3 Shields require recert every 2 years, or as specified by the manufacturer. SFI 6.2 and 6.3 Titanium Shields recert every year. SFI 6.1 Steel, and 9.1 shields must be re-certified every 5 years. The flywheel shield must be fastened to the engine and motor plate with a full complement (all available engine bolt holes or as specified by the manufacturer) of grade 8 (or Class 12.9) bolts or high-strength studs. The use of Allen bolts to fasten the shield to engine or motor plate, to fasten covers, etc., is prohibited. All bolts (not studs or nuts) used for flywheel shield mounting, covers, etc., must be identifiable as to grade; all nuts and bolts associated with flywheel shield mounting, covers, etc., must be full standard depth, width, etc. (reduced thickness bolt heads, hollow bolts, half nuts, thin wall nuts, etc prohibited). All covers and fasteners associated with the flywheel shield must be installed prior to starting engine at anytime, including warm-ups. Maximum spacing between flange fasteners in the flywheel shield is 7-inches (178 mm). Chemical milling or any other structure weakening procedures are prohibited. Welding to repair a flywheel shield is prohibited unless it is performed by the manufacturer and recertified by the manufacturer prior to use. Cooling holes in the motor plate are limited to a maximum of two 2-inch (51 mm) diameter holes (to be outside of the oil pan area). SFI 6.2 flywheel shields may have one 2-inch (51 mm) maximum diameter hole in the bottom of the back face of the shield. The opening in the motor plate for the crankshaft flange may not exceed the crankshaft flange diameter by more than 1.00 inch (25.4mm).

## GSR 2:10 FLYWHEEL SHIELD.

### Sportsman Classes 11.49 – 6.00 seconds.

Sportsman class cars using a clutch, must be equipped with an SFI Spec 6.1 (single-disc clutch) or 6.2 or 6.3 (multi-disc clutch) flywheel shield (bellhousing) labelled accordingly, complete with motor plate and full complement of bolts (all available engine bolt holes or as specified by manufacturer) of minimum 3/8-inch (9.53 mm) diameter grade 8 (or Class 12.9) bolts or high strength steel alloy studs above centreline of crankshaft. The motor plate must be fastened to the flywheel shield with at least eight 3/8-inch (9.53 mm) diameter grade 8 (or Class 12.9) bolts or high strength steel alloy studs and nuts below the centreline of the crankshaft. Modifications or repairs to the flywheel shield prohibited except if performed and recertified by manufacturer.

Exceptions to this rule: Some engines for which an SFI 6.1 or 6.2 Spec adapter shield is not commercially available, must be equipped with a flywheel shield made of 1/4-inch (6.35 mm) minimum thickness steel plate, securely mounted to the frame or frame structure and completely surrounding the bellhousing 360 degrees. The flywheel shield shall not be bolted to either the bellhousing or engine. The flywheel shield must extend forward to a point at least 1-inch (25.4 mm) ahead of the flywheel and 1-inch (25.4 mm) to the rear of the rotating components of the clutch and pressure plate. Other engines, where an SFI 6.1, 6.2 or 6.3 flywheel shield is not available, may use an SFI 6.1, 6.2 or 6.3 flywheel shield from another application and mount it to a motor plate which is mounted to the engine block at all available bolt holes.

In the event of non-availability of an SFI Spec 6.1, 6.2 or 6.3 Shield; Or of clearance/impracticability problems, the following options can be implemented.

### Transverse Engined Cars:

A fabricated 1/4 inch (6.0mm) thick, 6"x12" (150 x 320mm) approx, Steel Shield is permitted, fitted to the profile of the Firewall in line with the Flywheel/Clutch. The Shield must be secured to the Firewall with a minimum of six (6) 3/8 inch or 10mm 10.9 grade bolts and washers.

### Inline Engined 4 Wheel Drive Cars:

A fabricated 1/4 inch (6.0mm) thick 8" (205mm) wide Steel Shield is permitted, covering the Flywheel/Clutch area, fitted to the profile of the

Transmission Tunnel. Each side of the Shield shall be flanged 1.5 inches (36.0mm) and bolted to the Floor/Frame of the car with three (3) 3/8 inch or 10.00mm 10.9 grade bolts per side.

#### **GSR 2:11 REAREND.**

Welded spider gear rearends prohibited in all classes.

#### **GSR 2:12 TRANSMISSION.**

All cars and trucks in competition must be equipped with a reverse gear.

#### **GSR 2.13 TRANSMISSION, AFTERMARKET PLANETARY.**

A transmission shield covering transmission and reverser that meets SFI Spec 4.1 is mandatory. Air shifter bottles must be stamped with DOT - 1800 pound, or at a 124 bar rating (minimum), and be securely mounted (no tie wraps or hose clamps). At least three bolts, 3/8-inch (9.53 mm) minimum, must be used to secure aftermarket planetary transmissions to bellhousing.

#### **GSR 2:14 TRANSMISSION, AUTOMATIC.**

Any Non-OEM floor-mounted automatic transmission shifter must be equipped with a spring loaded positive reverse lockout device to prevent the shifter from accidentally being put into reverse gear. Functional neutral safety switch mandatory.

All transmission lines must be metallic or high-pressure-type hose. Triple-Barb Hose fittings mandatory. All vehicles running quicker than 9.99 seconds (\*6.39) or faster than 217 km/h (135 mph) and using an automatic transmission must be equipped with a transmission shield meeting SFI Spec 4.1 and labelled accordingly. "Blanket" type shield, appropriately labelled as meeting SFI Spec 4.1 permitted. All non blanket type shields must incorporate two (or one, per manufacturer's instructions) 3/4-inch (19.050 mm) x 1/8-inch (3.2 mm) straps that bolt to the shield on each side, and pass under the transmission pan, or transmission pan must be labelled as meeting SFI Spec 4.1. Permitted in all classes where an automatic transmission is used. 9.99 (\*6.39) or quicker cars, and 217 km/h (135 mph) or faster cars using an automatic transmission must be equipped with a flexplate meeting SFI Spec 29.1 and covered by a flexplate shield meeting SFI Spec 30.1. Only gas cylinders/ bottles certified for use at the working pressure (minimum 124 bar rating) of the system permitted (also applicable to any vehicle with a pressurised gas system). All receiving cylinders should have rupture disc or safety valve to prevent over pressurisation. All bottles must be securely mounted (hose clamps and/or tie wraps prohibited).

### **BRAKES & SUSPENSION. GSR 3**

#### **GSR 3:1 BRAKES.**

Brakes on each car, regardless of class, must be in good working order. Lightening of backing plates, brake drums and/or brake shoes by cutting or trimming metal prohibited. Cooling or lightening holes may not be drilled in cast iron disc brake rotors. Aluminium rotors prohibited. If hand brake is used, brake handle must be inside car's body or driver compartment. Brake lines must be steel, steel braided or DOT (DIN/ISO) approved flexible and routed outside the frame rail, or enclosed in a 16-inch (406 mm) length of 1/8-inch (3.2 mm) minimum wall thickness steel tubing securely mounted where line(s) pass the flywheel bellhousing area and not routed in the driveline tunnel. All brake lines must be attached to chassis as per OEM. Hoses must have mounting brackets; no tie wraps, tape, etc. Automated and/or secondary braking systems prohibited; application and release of brakes must be a direct function of the driver; electronics, pneumatics or any other device may in no way affect or assist brake operation. All pedals must be covered with non-skid material. FIA accepted mechanical anti-lock braking systems (ABS) permitted in all classes. If brake system includes a differential pressure switch, line-lock installed on front brakes must have solenoid installed after the differential switch. All line-locks (electric or hydraulic) must be self returning to normal brake operating mode. All master cylinder reservoirs situated in the drivers' compartment must be covered to prevent leakage onto the driver in the event of an upset.

#### **GSR 3:2 SHOCK ABSORBERS**

Each car in competition must be equipped with one operative shock absorber for each sprung wheel, securely mounted and in good working order. (See Class Requirements.)

#### **GSR 3:3 STEERING**

Each car's steering system must be secure and free of defects. All welded parts must have additional visible reinforcement. Only conventional automotive steering systems are permitted; flexible steering shafts prohibited. All rod ends must be a minimum of 3/8-inch (9.53 mm) shank diameter and must be installed with flat washers to prevent bearing pull out **See: PIC 12.**

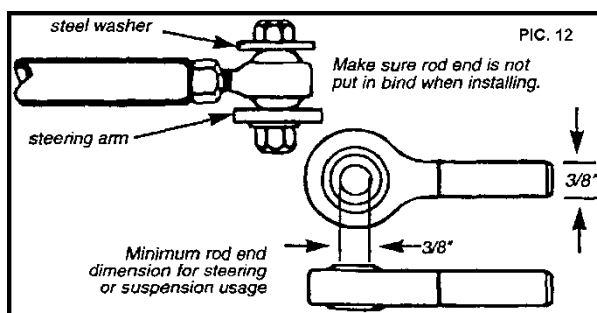

Hollow rod ends are prohibited. All steering boxes, sectors and shafts must be mounted to the frame or suitable crossmember and cannot be mounted in any case to the bellhousing and/or bellhousing adapter shield, motor plate or firewall. Commercially available quick-disconnect steering wheels permitted (except as noted in Class Requirements). All fasteners should be Hex Grade 5 or better, clearly identifiable. No set screws.

#### **GSR 3:4 SUSPENSION**

All cars must have a full suspension system of the type produced by an automobile manufacturer (i.e.: springs, torsion bars, etc.). All rod ends must be installed with flat washers to prevent bearing pullout. Hollow rod ends are prohibited.

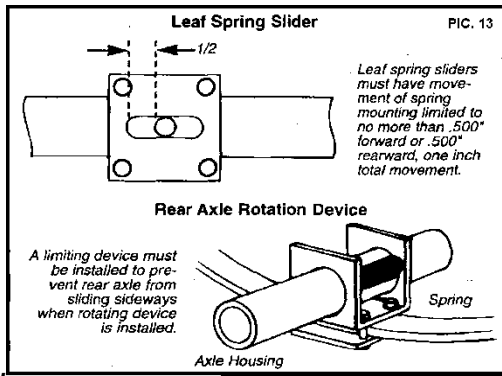

### GSR 3:5 TRACTION BAR ROD ENDS

Minimum requirement for rod ends on the front of all ladder-type traction bars is 3/4-inch (19.1 mm) thread 5/8 (16,87 mm) bore steel. A rod end strap to keep ladder bar secured in event of rod end failure mandatory in all classes. All traction devices that are not attached at front (i.e. slapper bars, etc.) must have a U-bolt or strap to prevent them from coming in contact with track. **See PIC: 14A, 14B and 14C**

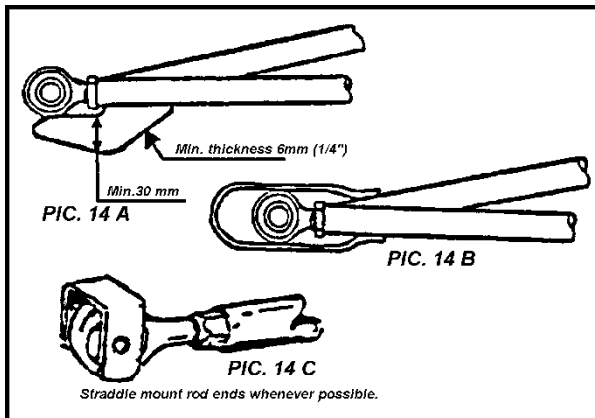

### GSR 3:6 WHEELIE BARS

Some classes limit length of wheelie bar - see Class Requirements. All wheelie bars, regardless of class, must have non-metallic wheels (i.e.: rubber, plastic). Using wheelie bar wheels as "fifth wheel" sensing device prohibited.

## FRAME: GSR 4

### GSR 4:1 ALIGNMENT

Each car in competition, regardless of class, must have sufficient positive front-end alignment to ensure proper handling of car at all speeds, and at braking.

### GSR 4:2 BALLAST

As permitted in Class Requirements. Any material used for the purpose of adding to a car's total weight must be permanently attached to the car's structure and must not extend behind or in front of the car's body or above the rear tires. No liquid or loose ballast permitted (i.e.: water, sandbags, rocks, shot bags, metal weights, etc.). Weight boxes (2 maximum) made of 1/8-inch (3.2 mm) material (**see illustration - PIC. 15**) may be constructed to hold small items such as shot bags, lead bars, etc., as long as box and contents do not weigh more than 100 pounds (45,36 kg) or as outlined in Class Requirements. The box must be securely fastened to the car's frame or crossmember with at least two 1/2-inch (12.7 mm) diameter steel bolts. Any liquid other than engine fuel being used, located behind the front firewall, (on a front engine car) is considered ballast, and is prohibited. To permit "making a class" due to the difference in scale calibration, a maximum removable weight of 100 pounds (45.4 kg) (or as outlined in Class Requirement) is permitted. Removable weight must be securely mounted to the frame or frame structure by a minimum of two 1/2-inch (12.7 mm) diameter steel bolts per 100 pounds (45.4 kg), or one 3/8-inch (9.53 mm) bolt per 5 pounds (2.3 kg). Hose clamps, wire, strapping, tape, tie wraps etc. for securing weight or ballast prohibited. See illustration for attachment method. Recommended forms of ballast are: 1) Heavier gauge steel floors such as 16 or 18-gauge (1.30 or 1.00 mm) (heavier gauge and/or plate steel prohibited); 2) Frame reinforcing crossmembers; or 3) The addition of protective equipment such as roll bars, flywheel shield, etc. If additional ballast is needed, and is permitted according to class requirement, it must be permanently attached to frame, bolted with two 1/2-inch (12.7 mm) diameter bolts per 100 pounds (45.36 kg), with nuts welded to bolts. Maximum amount of removable and/or permanent ballast, regardless of class, is 500 pounds (227 kg).



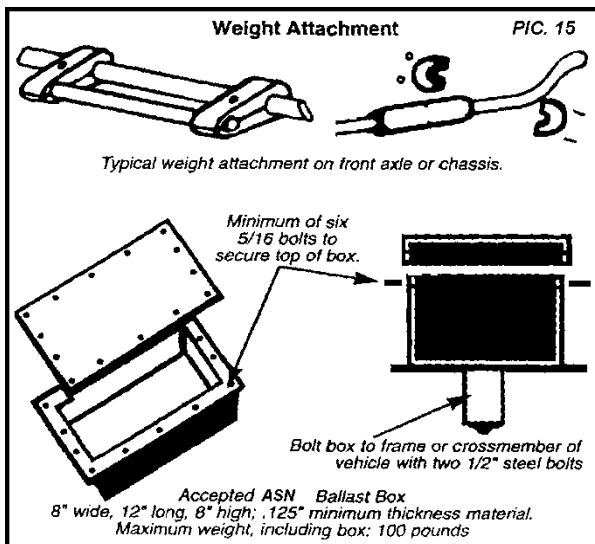

#### GSR 4:4 FRAMES

ALL CARS 9.99seconds and quicker, must have a serialised chassis sticker affixed to frame before participating in any event. Chassis certifications are available through MSA. Cars running 6.00 seconds or slower, chassis inspection every 36 months mandatory. Grinding of welds prohibited. All butt welds must have visible reinforcement (i.e. sleeve and rosette welds). Pressurisation of roll bar or roll cage in lieu of air bottles is prohibited. Visible reinforcement around any hole in any SFI spec chassis (not just the roll cage) mandatory. Reinforcement must be of at least the same cross sectional area as the hole, at least .049 inch (1.2 mm) thick chrome moly, and completely welded around the outside.

See 4:10 ROLL BARS and 4:11 ROLL CAGES.

#### GSR 4:5 GROUND CLEARANCE

Minimum 3-inches (76 mm) from front of car to 12-inches (305 mm) behind centreline of front axle, 2-inches (51 mm) for remainder of car, except oil pan and exhaust headers where permitted. When allowed under Class Requirements, devices used for anti-rotation purposes (i.e.: wheelie bars) are exempt from the two-inch (51 mm) clearance rule.

#### GSR 4:6 NON-DESTRUCTIVE TEST CERTIFICATES

Non-destructive test inspection certificates may be required by the scrutineer on any altered or welded parts.

#### GSR 4:7 MOUNTING HARDWARE

Hose clamps and tie wraps may only be used to support hoses and wires; all other components must be welded, bolted, aircraft clamped etc. All Dzus fastener must be metallic.

#### GSR 4:8 PARACHUTES

If outlined in Class Requirements, mandatory to have a braking parachute produced by a recognised drag racing parachute manufacturer. Scrutineers may observe the proper operation of the parachute and inspect for worn or frayed shroud lines, ripped or dirty canopies and worn or ragged pilot chutes. Parachute cable housings should be mounted solidly to frame tube or other suitable member no further back than 1-inch (25.4 mm). The release housing must be attached within 12-inches (305 mm) of the parachute pack and in a manner that will allow the inner cable to release the chute. When supercharged it is mandatory that the parachute pack and unpacked shroud lines be protected with fire-resistant material from the mounting point into the pack. Parachutes must have their own independent mounting. The use of ball-lock pins for parachute mounting and/or stop anchorage are prohibited. See Class Requirements regarding use of two parachutes. Such applications require separate shroud-line mounting points for each parachute system. **See PIC. 17.**

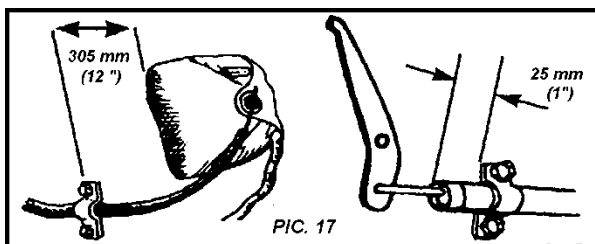

#### GSR 4:9 PINION SUPPORT

All cars using an open driveline must have radius arms, traction bars or some suitable pinion support to prevent rearend housing rotation. It is recommended that a torque tube, steel, 1/8-inch (3.2 mm) minimum wall thickness, be used to enclose all drivelines.

#### GSR 4:10 ROLL BARS (ET 11.99 to 10.00Secs)

All roll bars must be within 6-inches (152 mm) of the rear, or side, of the driver's head, extend in height at least 3-inches (76 mm) above the driver's helmet with driver in normal driving position, and be at least as wide as the driver's shoulders or within 1-inch (25.4 mm) of the driver's door. Roll bar must be adequately supported or cross-braced to prevent forward or lateral collapse of roll bar. Rear braces must be of the same diameter and wall thickness as the roll bar and intersect with the roll bar at a point not more than 127 mm (5-inches) from the top of the roll bar. Sidebar must be included on driver's side. The side bar must pass the driver at a point midway between the shoulder and elbow. All vehicles with OEM frame must have roll bar attached to frame; installation of frame connectors on unibody cars does not constitute a frame and therefore it is not necessary to have the roll bar attached to the frame. Unibody cars with stock floor and firewall (wheel tubs permitted) may attach roll bar with 150 mm (6-inch) x 150 mm (6-inch) 3 mm (0.125-inch) steel plates on top and bottom of floor bolted together with at least four 10.0 mm 3/8-inch bolts and nuts or weld main hoop to rocker sill area with 0.125 (3.2 mm) reinforcing plates. All 4130 chrome moly tube welding must be done by approved TIG

Heliarc process; mild steel ( or ST51) welding must be approved MIG wire feed or TIG heliarc process. Welding must be free of slag and porosity. Any grinding of welds prohibited. **See illustration (PIC. 18).** Roll bar must be padded anywhere driver's helmet may contact it while in driving position.

Adequate padding must have minimum 1/4-inch (6.35 mm) compression or meet SFI Spec. 45.1.

#### **GSR 4:10.1 ROLL CAGE 10.00 SECS AND SLOWER**

From 2018, any vehicle manufactured on or after 2010 by a recognised mass motor manufacturer, and having had no other modification with exception to the following:-

Air Filter and intake (not Turbo or Super Chargers).

Exhaust system.

ECU or Engine and transmission control.

Brake upgrades.

Running no quicker than 10.00 seconds or 149 mph on the ¼ mile, may run with no additional roll cage,

These vehicles must have no modifications what so ever to any part of the safety structure or chassis.

#### **GSR 4:10.2 MATERIAL & DIMENSIONS OF ROLL BAR.**

Roll bar must be made of minimum O.D. of 45 mm (1 ¾ inches) x 3 mm (0.118 inch) mild steel, or minimum OD 45 mm (1 ¾ inches) x 2,1 mm (0.083 inch) chrome moly.

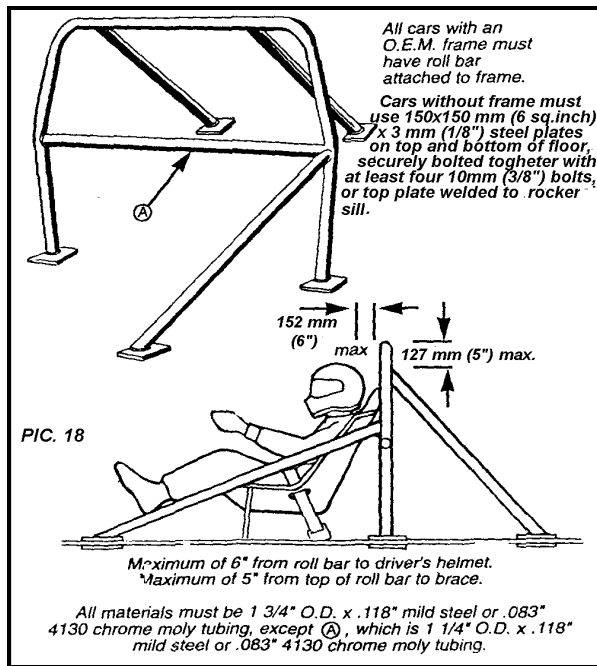

#### **GSR 4:11 ROLL CAGE (ET 9.99 TO 8.50Secs)**

Roll Cage: All cage structures must be designed in an attempt to protect the driver from any angle, 360-degrees and be fully welded. All 4130 chrome moly tube welding must be done by approved TIG heliarc process; mild steel tube welding must be approved MIG wire feed or TIG heliarc process. Welding must be free of slag and porosity. Any grinding of welds prohibited. Additionally, roll cage must be padded any where the driver's helmet may contact it while in the driving position. In Competition eliminator where SFI Spec on chassis is required, padding must meet SFI Spec. 45.1

#### **See illustrations (PICs. 19, 20 & 20a)**

On full bodied car, with driver in driving position, helmet must be in front of main hoop. If helmet is behind or under main hoop, additional tubing same size and thickness as roll cage must be added to protect driver. Main hoop may be laid back or forward but driver must be encapsulated within the required roll cage components

All cage structures must have in their construction a cross bar for seat bracing and as the shoulder harness attachment point; cross bar must be installed no more than 4-inches (102 mm) below, and not above, the driver's shoulders or to side bar. On 2 door road legal cars slower than 8.50 seconds the seat bar may be bolted in, as per diagram 20a. All required rear braces must be installed at a minimum angle of 30-degrees from vertical, and must be welded in. Side bar must pass the driver at a point midway between the shoulder and elbow.

On 2 Door Road Legal Cars, to allow rear passenger access, a removable Seat Bar is permissible, constructed as per Pic 20a.

Unless an O.E.M. frame rail is located below and outside of driver's legs (i.e. '55 Chevy, '65 corvette, etc.) a rocker or sill bar, minimum 1 5/8-inch (41.2 mm) x 0.083-inch (2.1 mm) chrome moly or 0.118-inch (3.0 mm) mild steel or 2-inch x 2-inch x 0.058-inch (50.8 x 50.8 x 1.5 mm) chrome moly or mild steel rectangular, is mandatory in any car with a modified floor or rocker box within the roll cage uprights (excluding six square feet (0.56 square meter) of transmission maintenance opening). Rocker bar must be installed below and outside of driver's legs, and must tie into the main hoop, the forward hoop, frame, frame extension or side diagonal. Rocker bar may not tie into swing out side bar support. If rocker bar ties into side diagonal more than 5-inches (127 mm) (edge to edge) from forward roll cage support or main hoop, a 1 5/8-inch (41.2 mm) x 0.083 (2.1mm) chrome moly or 0.118 (3.0 mm) mild steel brace/gusset is mandatory between the diagonal and forward roll cage support or main hoop.

Swing out bar permitted on O.E.M. full bodied car 8.50 seconds and slower.

- a. 1 5/8-inch (41.2 mm) O.D. x 0.083-inch (2.1 mm) (Chrome moly) or 0.118-inch (3.0 mm) (mild steel) minimum. Bolts/ pins must be 3/8-inch (9.5 mm) diameter steel, minimum and in double shear at both ends.
- b. Male or female clevises permitted. Male clevis must use two minimum 1/8-inch (3.2 mm) thick brackets (chrome moly or mild steel) welded to each roll cage upright; female must use minimum 1/4-inch (5.4 mm) thick bracket (chrome moly or mild steel) welded to each roll cage upright. Pins must be within 8-inches (204 mm) of the vertical portion of both the forward and main hoops. A half cup backing device must be welded to the vertical portion of the main hoop (inward side) or the upper end of the swing out bar (outward side), minimum 0.118-inch (3.0 mm) wall (chrome moly or Mild steel) extending at least 1 5/8-inch (41.2 mm) past the centre of the pins. A clevis assembly utilising a minimum 0.350-inch (8.9 mm) thick male components and two minimum 0.175-inch (4.45 mm) thick female components may use a 1/2-inch (12.7 mm) dia- meter grade 5 bolt, and does not require a half cup backing device.
- c. Sliding sleeves of 1 3/8-inch (35 mm) x 0.083-inch (2.1 mm) chrome moly or 0.118 (3.0 mm) mild steel, with minimum 2- inch (51 mm) engagement, are permitted in lieu of the upper pin/cup.
- d. All bolt/pin holes in the swing out bar must have at least one hole diameter of material around the outside of the hole. O.E.M firewall has been modified ( in excess of 1 square foot (929 cm2) for transmission removal, not including bolted in components) a lower windshield or dash bar of 1 1/4 x 0.058-inch (32 x 1.5 mm 4130 chrome moly or 1 1/4 x 0.118 (32 x 3.0 mm) mild steel is mandatory connecting the forward cage support.

Unless attaching to a OEM floor or frame, the minimum requirements for a frame member to which a roll cage member is attached are 1 5/8-inch x mild steel or .083-inch chrome moly round tubing, or 2-inch x 2-inch x 0.058-inch mild steel or chrome moly rectangular.

**GSR 4.11.1 FULL BODIED CARS.**

**EXCEPT WHERE SFI SPEC. 25.1E or SFI 25.4 IS MANDATORY (8.49 seconds and quicker).**

Roll cage must be manufactured in steel or chrome moly tubing. Minimum dimensions as in table for PIC. 19, 20 and 20a below.

	O.D.	Chrome moly	Mild Steel
A	42 mm (1 5/8 inch)	0,083 inch	3 mm (0,118 inch)
B-1	38 mm ( 1 1/2 inch)	0,058 inch	3 mm (0,118 inch)
B-2	35 mm (1 3/8 inch)	0,049 inch	3 mm (0,118 inch)
B-3	32 mm (1 1/4 inch)	0,049 inch	3 mm (0,118 inch)
C	32 mm (1 1/4 inch)	0,065 inch	3 mm (0,118 inch)
D	32 mm (1 1/4 inch)	0,058 inch	3 mm (0,118 inch)

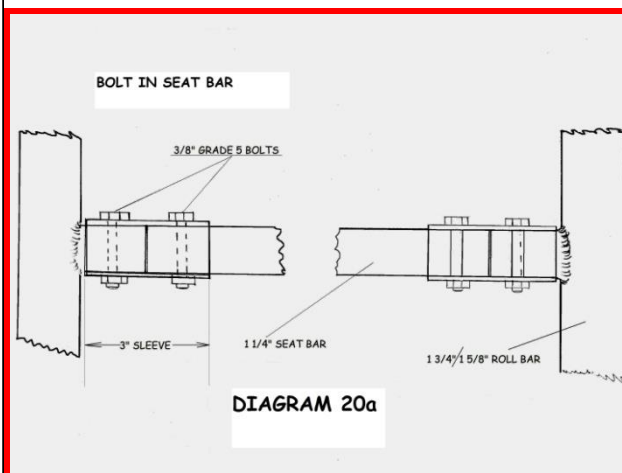
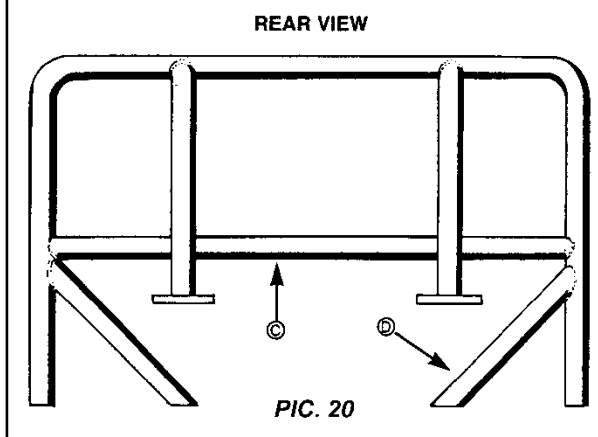
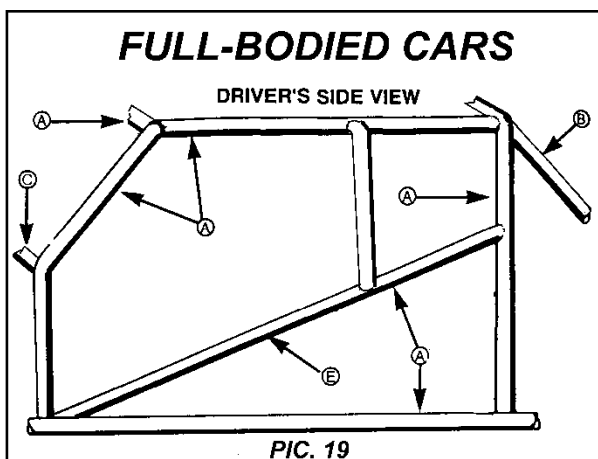

All cars with an O.E.M. frame must have roll cage welded to frame.

- B- If A, two bars any length  
If B1, 30" or less; must attach within 5-inches from top of main hoop.  
If B2, minimum 4 bars. At least 2 bars must attach to horizontal portion of main hoop.  
If B3, minimum 6 bars. At least 2 bars must attach to horizontal portion of main hoop.
- D- 32 mm (1 1/4") x 1.47 mm (0.058") 4130 chrome moly or 3mm (0.118") mild steel, mandatory when main hoop is welded to plates on floor, must be connected to sub frame.
- E- May substitute an "X" brace of 38 mm (1 1/2") x 1.65 mm (0.065") 4130 chrome moly or 38 mm (1 1/2") x 3 mm (0.118") mild steel.
- #6 Helmet bars in all vehicles, 1" x .058" chrome moly or 1" x .118" mild steel.

### Alternative main frame

Cars slower than 8.50 seconds; Main frame can be made of rectangular tubing minimum 60 x 40 x 3 mm (2 1/2" x 1 1/2" x 0.118").

N.B. Mild steel or chrome moly SFI chassis options for vehicles 7.50 secs or slower:-  
SFI 25.4 Tube frame Car 3600lbs max  
SFI 25.5 OEM frame Car 3600lbs max

## NOTE

Cars in Drag Race & Time Attack Competitions are required to have this ROLL CAGE constructed from 1 3/4in x .093in (45mm x 2.5mm) 4130 chrome moly or T45 tube, or 1 3/4in x .118in Mild Steel tube

### GSR 4:12 WHEELBASE

Minimum 2286 mm (90-inches). The exception to this is a car running no quicker than 10.50 seconds and which is based on a production vehicle having a original wheelbase of less than 2286 mm (90-inches). This vehicle must retain the original manufactures wheelbase. Maximum wheelbase variation from left to right is 25,4 mm (1-inch), unless otherwise noted in Class Requirements.

## TYRES & WHEELS: GSR 5

### GSR 5:1 TYRES

Tyre will be visually checked for condition, pressure, etc., and must be considered free of defects by the technical inspector prior to any run. All street tyres must have a minimum of 1.6 mm (1 1/16 inch) tread depth. Temporary spares, space saver spares, farm implement or trailer tyres prohibited. Metal, screw-in valve stems mandatory in tubeless tyres, front and rear, on cars running 11.00 sec or quicker. If not stated otherwise under class rules, cars running 200 km/h ( 124 mph) or faster must be equipped with front tyres classified minimum "HR" or with racing tyres type front-runners.

### GSR 5:2 WHEELS

Hubcaps must be removed for scrutineers, who will check for loose lugs, cracked wheels, worn or oversize lug holes, and condition of spindles, axle nuts, cotter pins, etc. Snap-on hubcaps are prohibited on any class car. Each car in competition must be equipped with automotive type wheels with a minimum 12-inches (305 mm) of diameter unless Class Requirements stipulate otherwise. Motorcycle wheels or lightweight automotive wire wheels must be equipped with .100-inch (2.5 mm) minimum diameter steel spokes, properly cross-laced to provide maximum strength. All spoke holes in rim and hub must be laced. Omissions to lighten wheels prohibited. All wheel studs must project into the hex portion of the lug nut by a distance equal to one diameter of the stud. Steel lug nuts mandatory. Maximum rim width on any car: 16-inches. No rear wheel discs or covers allowed in any category.

See PIC. 31

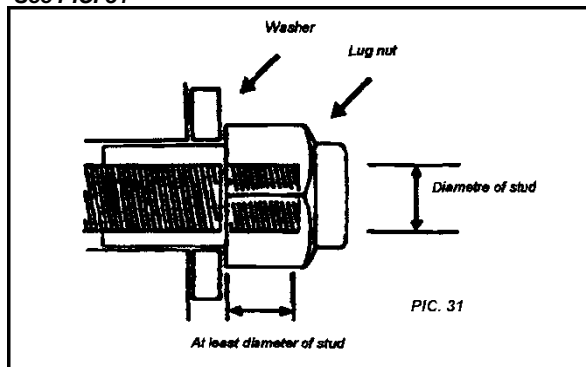

## INTERIOR: GSR 6

### GSR 6:1 DRIVER COMPARTMENT

All interior panels (firewalls, floors, wheel tubs, doors, etc.) within the driver compartment of enclosed-cockpit cars where the driver is located behind the engine must be constructed of materials other than magnesium. Driver compartment of any enclosed or full bodied car must be totally sealed from engine and transmission. All holes in firewall must be sealed with aluminium or steel. Openings around all linkages, lines, wires, hoses, etc. must be minimised. **See also GSR 7.5.**

### GSR 6:2 UPHOLSTERY, SEATS

The driver's seat of any car in competition must be constructed, braced, mounted, and upholstered so that it will give full back and shoulder support. The driver's seat must be supported on the bottom and back by the frame or crossmember. Except as noted in SFI specifications, seats must be bolted with four bolts and nuts and washers on the bottom and one bolt in the rear into crossbar; all bolts must go into frame or crossbraces, ball-pins for seat attachment prohibited. All seats must be upholstered, or as noted under Class or SFI Requirements. Properly braced, framed, supported and constructed seats of aluminium, Fibreglas or double layer poly (accessory seats) or carbon fibre are allowed. Single layer Fibreglas seats must have steel tube framework, 1/2-inch (12.7 mm) min outside diameter, for support. Aftermarket aluminium seats must have reinforced head rest. Magnesium seats prohibited. **See PIC. 32**

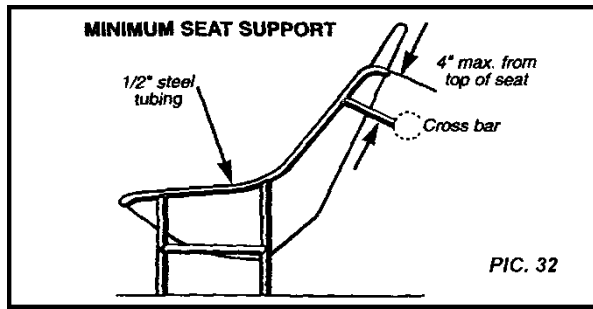

### **GSR 6:3 WINDOW NET**

A ribbon type or SFI spec 27.1 mesh type window net is mandatory on any full-bodied car required by the rules to have a rollcage. Window net must be securely mounted on the inside of the roll cage, with the permanent attachment at the bottom. All attachment points must be designed in an attempt to protect the driver and avoid contact with the track surface or guardwall/guard rail. Eyelet clips, dogleash, hose clamps, etc. prohibited. Penetration of webbing, except as performed by manufacturer, prohibited. See Class Requirements for any deviations.

## **BODY: GSR 7**

### **GSR 7:2 AIR FOILS, WINGS**

OEM Spoilers and Airfoils permitted. A positive locking device to prevent movement mandatory. No part to be within 6-inches (152 mm) of rear tires. Spring-loaded spoilers prohibited. Adjustment of spoilers during run prohibited.

NOTE: A spoiler is mounted directly to the deck lid of the vehicle, such that air only passes on the top side of the device. An airfoil on stands, struts or pedestals, such that air passes over the top and underneath the device.

### **GSR 7:3 COMPETITION NUMBERS**

Any car competing must display the driver's Competition number. Numbers must be a minimum 152 mm (6-inches high) and 38 mm (1 1/2-inches) wide. Class designation letters must be a minimum 76 mm (3-inches) high and 25,4 mm (1-inch) wide. Driver's competition number and class designation must be displayed in a legible manner in a contrasting colour to the vehicle's background colour, or light colour on windows, in a prominent position, and be clearly visible to the Tower personnel. Class and numbers must be in the form of permanent decals or paint. The use of shoe polish in any form is prohibited.

### **GSR 7:5 FIREWALLS**

Each car in competition must be equipped with a minimum 0.032-inch (0.8 mm) aluminium or 0.024 (0.6 mm) steel firewall, extending from side to side of the body and from the top of the engine compartment's upper seal (hood, cowl, or deck) to the bottom of the floor and/or bellypan. Firewall must provide a bulkhead between the engine and/or fuel tank and driver compartment. All openings must be sealed with metal. In certain instances fibreglass, carbon fibre or other composites may be used. See Class requirements or consult the Tech Inspectors. Use of magnesium prohibited.

### **GSR 7:6 FLOORS**

All cars without floors must be equipped with floor pans made of steel or aluminium which must extend the full length and width of the driver compartment to the rear of the driver's seat. Cars equipped with floors or bellypans made of Fibreglas or other breakable material must have metal subfloors. In all cars with OEM Fibreglas floors, a crossmember (minimum 51 mm (2-inches) x 51 mm (2-inches) 2,1 mm (0.083-inch) wall thickness square tubing) must be installed between frame rails for proper driver's seat, seat belt, shoulder harness and crotch strap installation. Bellypans and subfloors enclosing engine or driver compartment must contain suitable drain holes so that liquids and foreign matter cannot collect, thus creating a fire hazard. Minimum 0,8 mm (0.032-inch) aluminium or 0,6 mm (0 .024-inch) steel. In certain instances, a panel made of composite material may be substituted for steel or aluminium. Use of magnesium prohibited.

### **GSR 7:7 BONNET SCOOP**

On full-bodied cars, where allowed, bonnet scoop may not extend more than 11-inches (279 mm) above height of original bonnet surface. Scoop may have one inlet opening only. **See Class requirements for additional restrictions.**

### **GSR 7:9 WINDSHIELD, WINDOWS**

Windshields and/or windows on all cars, when called for under Class Requirements, must be of safety glass, Plexiglas, Lexan (Polycarbonate), or other shatter-proof material. Windshields and/or windows must be clear, without tinting or colouring, except factory-tinted safety glass. Competition number decals are allowed on any side or rear window.

## **ELECTRICAL/CONTROL: GSR 8**

### **GSR 8:1 BATTERIES**

All batteries must be securely mounted and may not be relocated into the driver or passenger compartments. Rear firewall of 0.6 mm (0 .024-inch) steel or 0.8 mm (0 .032-inch ) aluminium (including package tray) required when battery is re-located in Boot area. In lieu of rear firewall, battery may be located in a sealed 0.6 mm (0.024-inch) steel or 0,8 mm (0.032-inch) aluminium or FIA accepted poly box. If sealed box is used in lieu of rear firewall, box may not be used to secure battery, and must be vented outside of body. A maximum of two automobile batteries, or 68 kg (150 pounds) combined maximum weight are allowed. Metal battery hold-down straps mandatory. Strapping tape prohibited. Hold-down bolts must be minimum thread dia 10mm (3/8-inch) if battery is relocated from stock and other than stock hold-downs are used. (J hooks prohibited or must have open end welded shut.

### **GSR 8:2 DELAY BOXES/DEVICES**

A Delay Box or Delay Device is defined as any device (electric, electronic, pneumatic, hydraulic, mechanical, etc.) built for the express purpose of creating a delay between release of trans-brake or line-lock button, or release of foot or hand brake, or release of clutch pedal/lever, and the resultant action of the vehicle. Delay Device may only display delay amount dialled in, analogue or digital display allowed. See Class requirements for number of boxes/devices permitted. Delay device may only serve to create a pre-set delay between release of trans brake, line-lock, etc. and resultant action of vehicle. Delay device may only be connected to systems; i.e. trans brake, and/or line-lock, and/or clutch, dependant on vehicle, and throttle stop. Delay device connected to shift timers, data recorders, or any other equipment prohibited. Wiring of delay box/device must be fully visible, labelled and traceable to scrutineer. Only delay boxes/devices fitting this description will be allowed.

Any system that does not fit the above description is prohibited, and must be corrected before the vehicle will be passed through pre-event scrutineering. Further, discovery of a prohibited device at any time following pre-event scrutineering will be grounds for immediate disqualification from the event. (**See 9:1 COMPUTERS, 9:2 DATA RECORDERS**)

### GSR 8:3 IGNITION

Each car in competition must have a positive-action on/off switch, capable of de-energising the entire ignition system, in good working order, located within easy reach of the driver. "Momentary contact" switch prohibited. Magneto 'kill button'-type switches are prohibited.

### GSR 8:4 MASTER CUT-OFF

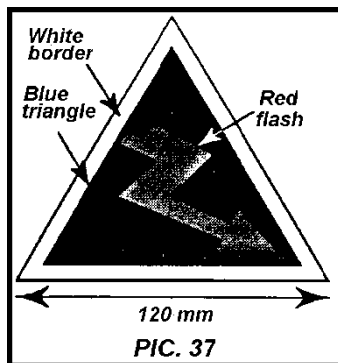

Mandatory when battery is relocated, or as outlined in Class Requirements. An electrical power cut-off switch must be installed on the rearmost part of each vehicle (except for Time Attack Cars) and be easily accessible from outside the car body. This cut-off switch must be connected to the positive side of the electrical system and must stop all electrical functions including magneto ignition. The positions must be clearly indicated with the word "OFF". If switch is "push/pull" type, push must be the action for shutting off the electrical system, pull to turn it on. Any rods or cables used to activate the switch must be minimum 1/8-inch (3.2 mm) diameter. Plastic or keyed switches prohibited. The external control switch for this cut-off switch will be clearly indicated by a red flash inside a white-edged blue triangle with a base of at least 120 mm. **See illustration PIC. 37.**

### GSR 8:5 STARTERS

All cars must be self-starting. Rollers and/or push starts prohibited.

### GSR 8:6 TAIL LIGHTS

All vehicles must have as minimum requirement one working tail light for night operations. Strobe, flashing, high intensity, laser, infrared, photo sensitive or other light emitting/receiving device prohibited. Any type of lights that may distract other drivers are prohibited. Also see Class Requirements.

## SUPPORT GROUP: GSR 9

### GSR 9:1 COMPUTER

Except those computers installed on stock vehicles by the new vehicle manufacturers for the proper operation of such vehicles, no vehicles may be equipped with computers which in any way effect the operation of the vehicle. Subject to class requirements, OEM or OEM-type electronic fuel injection permitted. All related wiring, sensors, etc. must be identifiable to the scrutineer. A computer is defined as any device (electrical, mechanical, pneumatic, hydraulic, etc.) that activates any function of, or in any way affects the operation of, the vehicle based on measurement, sensing, processing, etc., of any data related to the performance of the vehicle. Display or transmission of any data gathered or processed, to the driver or any remote location (telemetry), is prohibited (see 9:2 DATA RECORDERS).

Per class requirements timed or rpm activated shifters and the like permitted, but all automated functions must be preset before the run. Timer may only display timer amount dialled in, analogue or digital display permitted.

### GSR 9:2 DATA RECORDERS

Data recorders may be used to record functions of a vehicle, so long as they do not activate any function on the vehicle. Data Recorder may not be activated by the throttle, clutch, brake, etc., mechanisms, nor by the Christmas Tree, radio transmitters, sensing of wheel speed, inertia, laser device, or transmission of track position, must be activated by separate switch. Fifth wheel sensing devices prohibited on all vehicles (includes wheelie bar wheels). All lines sensing flow, pressure, etc., of fuel or oil must be metallic or steel braided. Transmission or display of data gathered or processed by data recorder, to the driver or any remote location, prohibited. Data may only be reviewed (print out, replay, etc.) after the run.

Any device (mechanical, hydraulic, pneumatic, electrical, optical, etc.) other than O.E.M. type, which assist in determining track location of the competitor's own vehicle or opponent's vehicle is prohibited. Only O.E.M. style mirrors, mounted in conventional fashion, permitted.

Discovery of a device which displays indicates or transmits "on track" or "track location", elapsed time type data will be grounds for immediate disqualification from the event

### GSR 9:3 FIRE EXTINGUISHER/SUPPRESSION SYSTEM

On-board fire-extinguisher system is mandated under certain Class Requirements. If a hand-held fire extinguisher is carried on board the vehicle, it must be mounted in a secure manner; flip-open type clamps prohibited. DRY POWDER TYPE PROHIBITED. On-board fire suppression systems must be manually controlled. Fire 302 or Fire X plus and mounted per manufacturer's specifications with the primary nozzle(s) directed in an attempt to protect the driver. Acceptable Total Flooding Agents (Feasible for Use in Occupied Areas) may be used. Bottles and lines must be mounted within the frame rails. Fire suppression bottle activation cables must be installed inside frame rail where cables pass engine/bellhousing area. Bottles must be certified for use at the working pressure and permanently mounted (no hose clamps or tie wraps). In the case of more than one bottle, each bottle must have its own distribution tubing and nozzles. The use of bottles, nozzles or tubing other than that recommended by the manufacturer is prohibited. Nozzle placement is extremely important; two nozzles are placed at the front of the engine, one on each side, and one nozzle is located in the driver compartment near the steering column, minimum. Upon activation of the system the contents of the bottle(s) must be totally discharged; partial-discharge systems prohibited. The bottles must be mounted in such a manner that should an explosion or failure of any mechanical component of the vehicle occur, the bottles will be protected from flying parts. Also, the position of the bottles in the vehicle must be high enough that they cannot come into contact with the track surface following loss of a tire or wheel. They should be protected from excessive temperature and mounted rigidly to the vehicle. Remote cables must be metallic (plastic or plastic-wrapped cables prohibited) and installed so they are protected in the event of an upset or collision. Follow the manufacturer's recommendations regarding installation, especially on bend radius and protection from crimping or kinking. All fire suppression systems must use steel lines, steel or aluminium distribution nozzles and must be equipped with a pressure gauge. All bottles must be identified with a gross loaded weight figure. It is the responsibility of the competitor to weigh the bottle prior to each event. If there is an external lever for activating the extinguishers, this must be clearly indicated.

### GSR 9:4 JACKS & JACKSTANDS

No work may be done under any car in the pit area while the car is supported by only one jack. Additional safety devices such as jackstands are mandatory to provide additional protection in the event of jack failure. Failure to observe this rule is grounds for immediate disqualification. Jack stand devices must be constructed as to provide a minimum ground clearance of 178 mm (7-inches) as measured from the ground to the outer diameter limit of the rear tires.

### GSR 9:5 LIFTING DEVICES

Any form of mechanical, hydraulic or other leverage-type device for raising a car's driving wheels off the starting line surface is prohibited.

### GSR 9:7 PRESSURISED BOTTLES

Only gas cylinders/bottles certified for use at the working pressure (minimum 124 bar rating) of the system as a fuel reservoir permitted (also applicable to any vehicle with a pressurised gas system). All receiving cylinders should have rupture disc or safety valve to prevent over pressurisation. All bottles must be securely mounted (hose clamps and/or tie wraps prohibited).

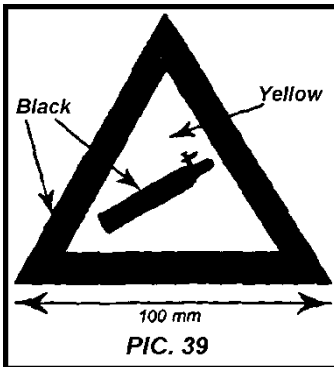

### GSR 9:8 PUSH BARS

Push or tow starts prohibited.

### GSR 9:9 TOW VEHICLE

Any vehicle used as a tow vehicle must have the driver's Competition Number displayed on the tow vehicle. Limit of six crew members in push-tow vehicle. Crew members must be inside cab or completely inside bed or truck, not to be seated on tailgate, standing on running boards or otherwise not completely inside vehicle.

### GSR 9:1 TWO-WAY RADIO COMMUNICATION

The use of two-way radios for the purpose of voice communication between driver and crew is acceptable in all classes. Telemetry may in no way be used for gathering data or performing control functions.

### GSR 9:11 WARM-UPS

It is mandatory that a driver be seated in the car in the normal driving position any time the engine is running. The practice of transbrake testing, converter stalls, line loc testing, and/or transmission warming is prohibited in all classes, in all areas of the event except in starting line approach areas beyond staging, or unless vehicle is on jack stands. Non-compliance is ground for disqualification

## DRIVER: GSR 10

### GSR 10:1 APPAREL

Each member of a participant crew must be fully attired when present in the staging, starting and competition areas of the race track. Shoes are mandatory. Shorts, bare legs, tank tops, or bare torsos are prohibited when driving in any class.

### GSR 10:2 APPEARANCE

Vehicles participating in drag racing events must be presentable in appearance at all times; those considered improperly prepared may be rejected by the race director. The appearance of personnel attending contestant vehicles is equally important, and is subject to the same considerations.

### GSR 10:3 ARM RESTRAINTS

Where mandated by Class Requirements, arm restraints must be worn and adjusted in such a manner that driver's hands and/or arms cannot be extended outside of roll cage and/or frame rails. Arm restraints shall be combined with the driver restraint system such that the arm restraints are released with the driver restraints, Refer to manufacturer for instructions.

### GSR 10:5 DRIVER RESTRAINT SYSTEMS

A quick-release, 76 mm (3-inch) driver restraint system meeting SFI Spec 16.1, is mandatory in all cars in competition required by the rules to have a roll cage (permitted in all other classes). Driver restraint system must be clearly labelled as meeting SFI Spec 16.1 and be dated by manufacturer. System must be updated at two-year intervals from date of manufacture in all cars. All seat belt and shoulder harness hardware and produced by the same manufacturer, and originally designed to be used with each other. For harness installation, **see illustration (PIC 40)**. Cars using OEM or OEM-type seat may route crotch strap in front of seat instead of through seat. Only those units that release all five attach points in one motion are permitted. When arm restraints are worn with a restraint system that utilises a "latch lever", a protective cover must be installed to prevent arm restraint from accidentally releasing the latch lever. Protective cover not required if system utilises "duck-bill" latch hardware. All harness sections must be mounted to the frame, crossmember, or reinforced mounting, and installed to limit driver's body travel both upward and forward. .

It is acceptable that all seats be mounted vertically and incorporate a compatible crotch strap. Under no circumstances are bolts inserted through belt webbing acceptable for mounting. Check manufacturer's instructions.

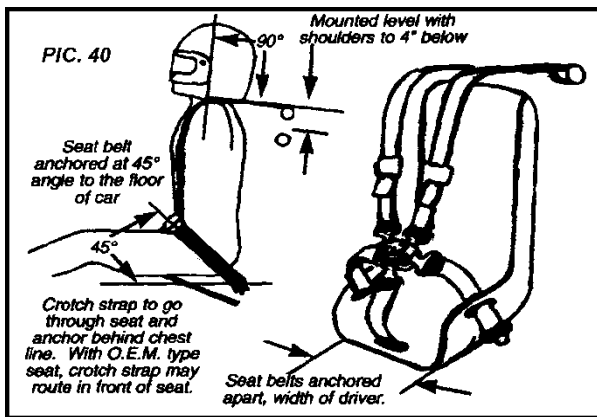

#### GSR 10:6 HEAD PROTECTOR

In any car where a roll bar, or roll cage is installed, a padded head protector must be provided at the back of the driver's head and constructed in an attempt to prevent whiplash upon impact. The roll bar or cage must be padded wherever it may come in contact with the driver's helmet. Adequate padding should permit approximately 6 mm (1/4-inch) or meet SFI Spec 45.1. For chassis that have to meet SFI chassis specs, padding meeting SFI 45.1 is mandatory. The use of weather stripping and similar thin or low impact resisting materials is prohibited. A padded roll bar or cage alone is not acceptable as a padded head protector unless it is within 102 mm (4-inches) of the driver's helmet. A seat that incorporates a reinforced head rest is acceptable. **See**

PIC 41.

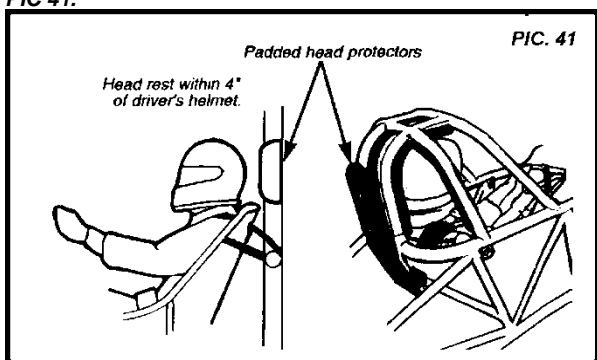

#### GSR 10:7 HELMETS & GOGGLES.

Drivers of any open bodied car wearing an "open face" helmet, must wear "racing type" protective goggles and a dual eye port, flame retardant balaclava. If a "closed face" type helmet is worn the balaclava is still required. Modifications to helmet/visor/shield are prohibited. All helmets must have the appropriate certification sticker affixed inside the helmet. See also class requirements.

#### GSR 10:8 NECK COLLAR.

Must be commercially produced neck collar designed for racing. Two different types of collars are commercially available - a full 360-degree "donut" type or a pull-together "horseshoe" type - see Class Requirements for type specified. Modification according to manufacturer's recommendations, to fit helmet and driver's neck/shoulder spacing, permitted. Must be worn as per manufacturer's recommendations. Must meet SFI Spec 3.3 as per Class Requirements.

#### GSR 10:9 OCCUPANTS.

No more than one person is permitted in any car during any run. All occupants of push cars must be inside of car or pickup in a seated position while push car is in operation. Any time a car is started, whether in the pits, staging lanes, with self-starter, or anywhere else on the race facility, a competent driver must be in the driver's seat, unless coupler or driveline is removed. Non-compliance is grounds for disqualification.

#### GSR 10: 10 PROTECTIVE CLOTHING 7.50 SECONDS OR SLOWER:

Shorts, bare legs, tank tops, or bare torsos are not acceptable when driving in competition. Gloves mandatory.

**NOTE:** A Suit is defined as :- **Gloves, Suit and Boots.**

**All unblown vehicles running 10.00 seconds or slower:** All drivers, jackets or suit meeting SFI spec 3.2A/1 or 1986 FIA standard mandatory. Note that the MSA do not accept "PROBAN".

**Vehicles running 9.99 to 7.50 seconds or any vehicle exceeding 135 mph:** Jacket and pants or suit meeting SFI spec 3.2A/5 or 1986 FIA standard mandatory. Note that the MSA do not accept "PROBAN".

**All Open Body Vehicles running 11.99 or quicker:** Gloves meeting SFI spec 3.3/1 or 1986 FIA standard and arm restraints mandatory.

**9.99 to 7.50 seconds** Front engine open bodied or closed bodied car without an OEM or steel firewall, with nitrous oxide and/or supercharger/ turbocharger: Jacket and pants or suit meeting SFI spec 3.2A/15, gloves and shoes/boots meeting SFI spec 3.3/5 mandatory.



**ET 10.7.1 PROTECTIVE CLOTHING 7.49 SECONDS AND QUICKER:**

**Front engine, supercharged or turbocharged, closed bodied car, OR any car with an automatic transmission in driver compartment (no floor covering transmission):** Jacket and pants or suit meeting SFI spec 3.2A/15, gloves meeting SFI spec 3.3/5 and boots or shoes meeting SFI spec 3.3/15 mandatory.

**Front engine, supercharged or turbocharged open bodied car:** Jacket and pants or suit meeting SFI spec 3.2A/20, gloves meeting SFI spec 3.3/5 and boots or shoes meeting SFI spec 3.3/15 mandatory.

**Front engine car equipped with nitrous oxide:** Jacket and pants or suit meeting SFI spec 3.2A/15, gloves meeting SFI spec 3.3/5 and boots or shoes meeting SFI spec 3.3/5 mandatory.

**Rear engine car equipped with nitrous oxide and/or turbocharged or supercharged:** Jacket and pants or suit meeting SFI spec 3.2A/15, gloves meeting SFI spec 3.3/5 and boots or shoes meeting SFI spec 3.3/5 mandatory.

**Naturally aspirated car: i.e. all others:** Jacket and pants or suit meeting SFI spec 3.2A/5 or 1986 FIA standard and gloves meeting SFI spec 3.3/5 or 1986 FIA standard mandatory.

**GSR: 10:11 SEAT BELTS.**

All cars not required by Class Requirements to use SFI Spec 16.1 driver restraint system must be equipped with an accepted quick release-type driver seat belt. Belts must be securely fastened to the frame, crossmember or reinforced mounting so that all fittings are in a direct line with the direction of pull. Steel castings of the type recommended by FAA, or U-bolt-type mounts are accepted. If used for installation, flat steel plates must be a minimum of 1/4-inch (6.35 mm) thickness and have rounded edges to prevent cutting seat belts. Under no circumstances can belts be installed with bolts through webbing. In all cars with Fiberglas floors, a crossmember of minimum 2-inch (51 mm) x 2-inch (51 mm) x .083-inch (2.1 mm) wall thickness square tubing must be installed between frame rails for proper driver's seat belt installation. All cars in competition requiring a roll cage as outlined by Class Requirements, require a SFI 16.1 restraint system.

**(See 10:5 DRIVER RESTRAINT SYSTEM).**

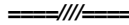

## CHARTS & FORMULAS

**Displacement** = bore x bore x stroke x .7854 x # of cyl.

**Volumes:**

bore x bore x 12.87 x depth of deck clearance = volume (cc's) of deck clearance  
bore x bore x 12.87 x thickness of head gasket = volume (cc's) of head gasket

**Compression Ratio** =  $\frac{\text{Deck CI CC's} + \text{Displacement} \times *2.0483}{\text{Comb Chamber CC's} + \text{Gasket CC's} + \text{Deck CI CC's}}$

\*2.0483 for 8 cyl. \*2.7311 for 6 cyl. \*4.0967 for 4 cyl.

$\pi$  = pie  $\pi = 3.1416$

radius<sup>2</sup> = radius x radius

**Circumference** =  $\pi \times \text{diameter}$

**Area of Circle** =  $\pi \times \text{radius}^2$

**Volume of Cylinder** =  $\pi \times \text{radius}^2 \times \text{height}$

### **Weights**

Oil	1 gallon	=	8.33 lb
Petrol	1 gallon	=	7.4 lb
Nitro	1 gallon	=	11.25 lb
Alcohol	1 gallon	=	8 lb
Water	1 gallon	=	10 lb

Above weights are for UK gallons 1.19 US gall = 1 UK gall

Titanium is 57% of weight of steel

Aluminium is 35% of weight of steel

Magnesium is 22% of weight of steel

### **METRIC & STANDARD CONVERSION**

#### **Length**

1 Kilometre = 1000 metres = 3,280.83 ft = .6215 mile

1 Metre = 100 centimetres = 39.37 in = 1.09 yards

1 Centimetre = .3937 inch

1 Mile = 1.609 kilometres

1 Yard = .91 metres

1 inch = 2.54 centimetres

1 inch = 25.4 millimetres

#### **Mass**

1 kilogram = 1,000 grams = 2.2045855 lbs

1 lb = 453.6 grams

1 ounce = 28.35 grams

lbs x 2.20 = kilos

kilograms/2.20 = lbs

#### **Volume**

1 litre = 100 cubic centimetres = 61.025 cubic inches

1 cubic inch = 16.387 cubic centimetres

## Contact Names

### **THE MOTOR SPORTS ASSOCIATION (MSA)**

MOTOR SPORTS HOUSE, RIVERSIDE PARK  
COLNBROOK, SLOUGH, SL3 0HG

Tel: 01753 681736

Fax: 01753 682938

### DRAG STRIPS

### **SANTA POD RACEWAY**

Unit 5, Airfield Road  
Podington, Wellingborough  
Northants, NN29 7XA

Tel: 01234 782828

Fax: 01234 782818

Email: [info@santapod.com](mailto:info@santapod.com)

Web: [www.santapod.com](http://www.santapod.com)

### SANTA POD RACERS CLUB

PO. Box 12 Rushden

Northants, NN10 0ZU

Tel: 01933 313625

Fax: 01933 355558

Email: [paula.marshall@btconnect.com](mailto:paula.marshall@btconnect.com)

Web: [www.eurodragster.com/sprc](http://www.eurodragster.com/sprc)

### DRAG RACING CHASSIS INSPECTORS

#### **SFI Approved Chassis Inspectors:**

Geoff Martin - 01608 674121 (Mobile): 07811 678798

Mark Norton - 01865 400812 (Mobile): 07881 456314

#### **National Chassis Inspectors:**

Geoff Martin - 01608 674121 (Mobile): 07811 678798

Mark Norton - 01865 400812 (Mobile): 07881 456314

### WEB LINKS

#### **Series Links:**

[www.SantaPod.com](http://www.SantaPod.com) - Racetrack info and other events

#### **Event Links:**

[www.Big-Bang.co.uk](http://www.Big-Bang.co.uk) - Big Bang

[www.StreetNationals.co.uk](http://www.StreetNationals.co.uk) - Street Nationals

[www.JapShow.com](http://www.JapShow.com) - JapShow June and Finale

[www.GOTP.co.uk](http://www.GOTP.co.uk) - God of the Pod

[www.RWYB.com](http://www.RWYB.com) - Test days and Run What Ya Brung info

#### **Chassis Builders and Drag Racing Safety Equipment:**

*Specialist advice and installation of drag racing roll cages and other safety equipment*

[www.webster-race-engineering.co.uk](http://www.webster-race-engineering.co.uk) - Webster Race Engineering, Rushden

[www.robinson-race-cars.co.uk](http://www.robinson-race-cars.co.uk) - Andy Robinson Race Cars, Basingstoke

[www.hauserracing.com](http://www.hauserracing.com) - Hauser Race Cars, Northants

[www.adrenaline-race.com](http://www.adrenaline-race.com) - Adrenaline Race & Performance, Rushden

[www.fgrmotorsport.co.uk](http://www.fgrmotorsport.co.uk) - FGR Motorsport, Airfield Road near Santa Pod

#### **Engine and Performance Specialists:**

[www.tdi-north.com](http://www.tdi-north.com)

[www.cpltracing.co.uk](http://www.cpltracing.co.uk) - Honda Specialist

[www.gtart.co.uk](http://www.gtart.co.uk)

[www.sumopower.com](http://www.sumopower.com) - Parts Only

[www.perfect-touch.co.uk](http://www.perfect-touch.co.uk)

[www.abbeymotorsport.co.uk](http://www.abbeymotorsport.co.uk) - Skyline Specialist

[www.rktuning.com](http://www.rktuning.com) - Skyline Specialist

[www.fensport.co.uk](http://www.fensport.co.uk) - Toyota Specialist

[www.reworx.com](http://www.reworx.com) - Mazda Rotary Specialist

[www.rxmotors.co.uk](http://www.rxmotors.co.uk) - Mazda Rotary Specialist

[www.xs-power.co.uk](http://www.xs-power.co.uk) - Parts Only

[www.fusion-motorsport.co.uk](http://www.fusion-motorsport.co.uk)



**Santa Pod Raceway**

Airfield Road, Podington  
Wellingborough, Northants NN29 7XA  
England

Tel: +44 (0) 1234 782828

Fax: +44 (0) 1234 782818

Email: [info@santapod.com](mailto:info@santapod.com)